

alcatel 1021

Note:

This is a user manual for Alcatel T319E.

This document is for reference only. The actual product (including but not limited to color, size, screen layout, etc.) may differ from the description depending on the region, service provider, or software version. This document is subject to changes without prior notice. Please refer to the actual product for accurate details. All statements, information and recommendations in this document do not constitute any form of warranty, whether express or implied.

Consulting FAQ

Go to <https://www.alcatelmobile.com/support/>

Finding your serial number or IMEI

You can find your serial number or International Mobile Equipment Identity (IMEI) on the packaging materials. Alternatively, choose **Settings** > **Regulatory & safety** > **IMEI** on the phone itself.

Obtaining service

First follow the advice in this guide or go to <https://www.alcatelmobile.com/contact-us/>. Then check hotlines and repair centre information.

Viewing legal information

On the phone, go to **Settings** > **About** > **Privacy and User Terms**.

Table of Contents

1	Your mobile	5
1.1	Keys and connectors.....	5
1.2	Getting started.....	9
1.3	Home screen.....	13
1.4	App list	13
2	Call logs	15
2.1	Making a call.....	15
2.2	Answer or decline a call	16
2.3	Accessing voicemail	16
3	Message	17
3.1	Write message.....	17
3.2	Send a multimedia message.....	18
3.3	How to type a message.....	18
4	Contacts	20
4.1	Consult your Contacts.....	20
4.2	Adding a contact.....	21
4.3	Editing your contacts.....	21
4.4	Deleting a contact	22
4.5	Available options.....	22

5	Calendar	24
6	Gallery.....	24
7	Camera.....	25
	7.1 Camera	25
	7.2 Video	25
8	Tools	26
	8.1 Alarm	26
	8.2 Clock.....	26
	8.3 Torch.....	26
	8.4 Bluetooth.....	26
	8.5 Calculator	26
	8.6 Recorder.....	27
	8.7 My files.....	27
	8.8 Call Filter.....	27
	8.9 Convert	27
9	STK	27
10	Settings.....	28
	10.1 Call settings.....	28
	10.2 Phone settings.....	28
	10.3 Display.....	29
	10.4 Security	30
	10.5 Profiles	31
	10.6 Connections	31
	10.7 Voice report	31

10.8	Battery Saver	31
10.9	Regulatory & Safety	32
10.10	About.....	32
11	Troubleshooting.....	33
12	Specifications	38
13	Accessories	39
14	Licences	39

1 Your mobile

1.1 Keys and connectors

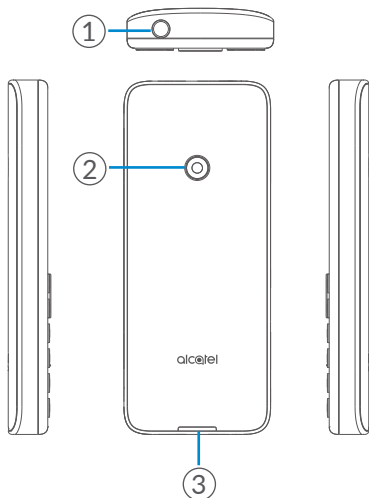

1. Torch
2. Camera
3. USB port

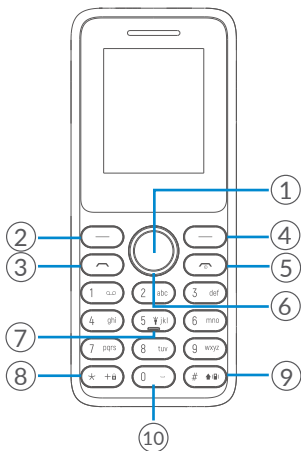

1. OK key

- Confirm an option (press the middle of the key)
- Press: access to the app list (from Home screen)

2. Left soft key

- Confirm an option
- Press: access to the app list (from Home screen)

3. Call key

- Pick up/send a call
- Press: enter call log (from Home screen)

4. Right soft key (Back key)

- Press: access to Contacts (from Home screen)

5. End key

- Return to Home screen
- Press: end a call

6. Navigation key

- Move to top, bottom, left or right menus.

Press (from Idle screen):

- Up: to access Message
- Down: to access Camera
- Right: to access Entertainment
- Left: to access Tools

7. "5" key

In idle screen:

- Press: Input "5"
- Long press: switch on/off the torch

8. "*" key

In idle screen

- Press: Input "*"
- Long press: lock screen

In Edit mode:

- Press: insert symbols

9. “#” key

Idle screen

- Press: Input “#”
- Long press: Vibrate mode on/off

In edit mode

- Press: Change the input method

1.2 Getting started

1.2.1 Set up

- ① With the device facing down, remove the back cover by using your fingernail to carefully lift the cover from the device body.
- ② To insert SIM card or micro SD card, push the SIM card or micro SD card into the card slot with the gold-colored contacts facing down. Power off your phone before inserting or removing the SIM/micro SD card.
- ③ Insert the battery by connecting the gold contacts in the device battery cavity. The battery will only fit one way.
- ④ Carefully align the back cover with tabs and press into place. It only fits one direction.

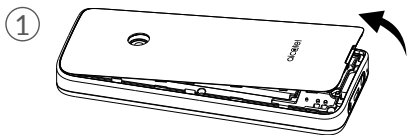

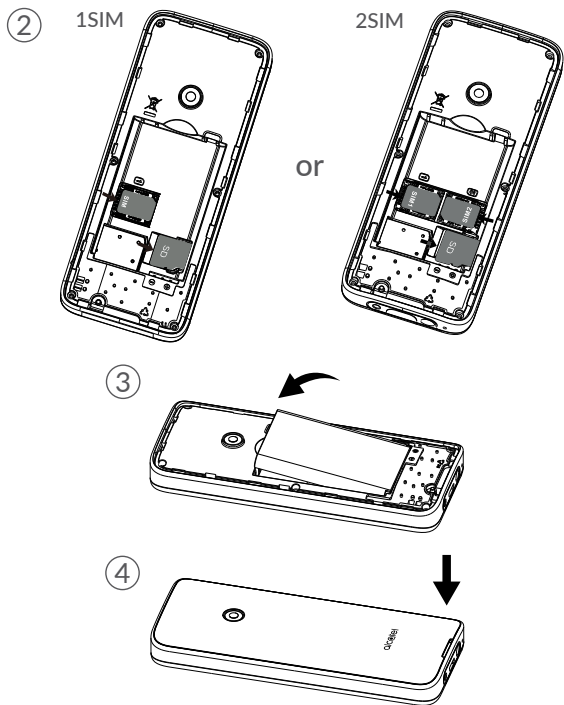

Charging the battery

Connect the battery charger to your phone and plug into the socket.

- Be careful not to force the plug into the socket.

- Make sure the battery is correctly inserted before connecting the charger.
- The mains socket must be near to the phone and easily accessible (avoid electric extension cables).

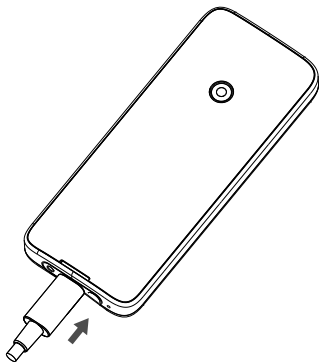

Learn more about battery life and proper use to maximise your battery's performance.

- Don't use or place your device in extreme temperatures. Extreme temperatures, whether too high or too low, can accelerate battery degradation and reduce its overall lifespan. For optimal performance, the manufacturer's recommended operating temperature range is 0°C (32°F) to 40°C (104°F).
- Deactivate Bluetooth when not in use.
- Deactivate auto-syncing of apps, close unnecessary apps.

- Turn display off by pressing the power key when the device is not in use.
 - Set Screen timeout to a short interval.
 - Lower the screen brightness.
 - After charging 100%, disconnect charger from the plug. Do not keep device constantly under charge, this will reduce the battery life.
 - Think of activating your phone's Battery Saver (**Settings > Battery Saver**) for a longer battery life.
- Battery capacity and usage hours may vary depending on device settings and usage patterns.

1.2.2 Power on your phone

To turn your phone on, hold down the **End** key until the phone powers on. It will take a few seconds before the screen lights up. Long press/Press⁽¹⁾ **Left soft key** to unlock your phone.

Even if no SIM card is installed, your phone will still power on and you will be able to use some of the phone's features.

1.2.3 Power off your phone

To turn your phone off, hold down the **End** key.

⁽¹⁾ Depending on the device you purchased.

1.3 Home screen

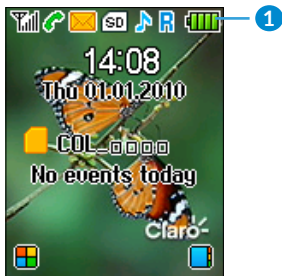

1 Status bar

- Status/Notifications

1.4 App list ⁽¹⁾



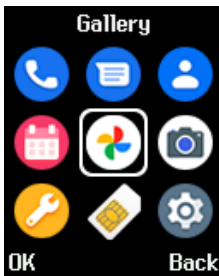



Press the **Left soft key** or **OK key** from the Home screen to access the App list.



⁽¹⁾ App list varies according to country and operator.

1.4.1 Status bar ⁽¹⁾

The Status bar appears at the top of your Home screen. Icons indicate your phone's status and new notification alerts appear in the Status bar.

	New message or multimedia message		No SIM card installed
	Silent mode		Alarm is set
	Level of network reception		Bluetooth is on

1.4.2 Change Home screen wallpaper

- From the Home screen, press the **OK key**, select the **Settings** icon , and then press the **Navigation key** to select **Display > Wallpaper settings**.
- Select a new image from **Static wallpaper** or **More pictures** and press the **Left soft key** to select. Exit and the new image will then be displayed on your Home screen.

⁽¹⁾ The icons and illustrations in this guide are provided for information purposes only.

2 Call logs.....

2.1 Making a call

Dial the desired number, press the **Call key** to place the call, or press the **Right soft key** from Home screen to select a contact from **Contacts**. Use the up or down action of the **Navigation key** to select the desired contact and press the **Call key**. If you make a mistake, you can delete the incorrect digits by pressing the **Right soft key**. To hang up the call, press the **End key**.

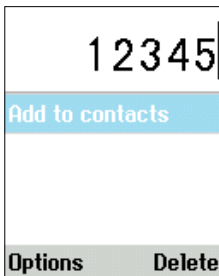

International call

To dial an international call, press ***+*** twice to enter "+", then enter the international country prefix followed by the full phone number and finally press the **Call key**.

Emergency call

If your phone has network coverage, dial the emergency number and press the **Call key** to make an emergency call.

2.2 Answer or decline a call

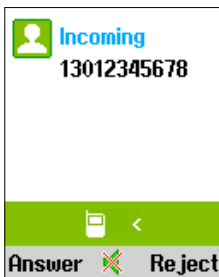

When you receive a call:

- Press the **Left soft key** or **Call key** to answer.
- Press the **Right soft key** or **End key** to decline.

2.3 Accessing voicemail ⁽¹⁾

- Press and hold **1** to call voicemail.
- Follow the prompts to set up your voicemail account.

⁽¹⁾ Contact your network operator to check service availability.

3 Message.....

Use the messaging feature to send and receive text (SMS/MMS) messages.

3.1 Write message

- From the Home screen, press the **OK key** and select **Messages > Write message**.
- Enter the phone number of the recipient in the **To** bar or press the **Centre soft key** to add recipients.
- Press the **Message** bar to enter the text of the message.
- When finished, press the **Centre soft key** to send your messages.

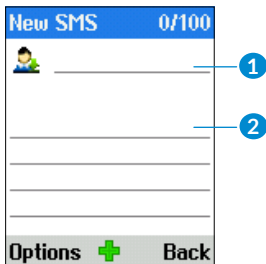

- 1 To bar
- 2 Message bar

3.2 Send a multimedia message⁽¹⁾

MMS enables you to send video clips, images, photos, contacts and sounds. On the message writing screen, select **Options** and select the attachment.

An SMS will be converted to MMS automatically when media files (image, video, audio, etc.) are attached.

3.3 How to type a message

When in edit mode, you can press the Keypad to change the input method to access numbers 1,2,3... or long press the corresponding key to get the number you want.

You can enter text using predictive text input, or press # to set your desired text input.

- For normal text input, press a number key, 2-9, repeatedly until the desired character is displayed. If the next letter you want is located on the same key as the present one, press the key repeatedly until the next cursor is displayed.
- Press the **#** key to choose Abc/abc/ABC/123 modes or write language.
- To insert a punctuation mark or special character, press the *** + #** key.
- If you want to delete any previously typed letters or symbols, press the **Right soft key** to delete them one by one.

⁽¹⁾ Depending on the device you purchased.

Settings

In your message screen, select **Options** to go to settings.

- SIM1/SIM2 Message centre

You can view your message centre number here.

- Message validity period

You can set your message validity period as 1 hour, 6 hours, 24 hours, 72 hours, 1 week or Maximum.

- Status report

You can choose to enable or disable status reports.

- Save sent messages

You can choose to save or not save the sent messages.

- Preferred storage

Set the path for the location of your saved messages.

4 Contacts.....

4.1 Consult your Contacts

Contacts enables quick and easy access to the contact you want to reach.

You can access this function through any of the following methods:

- pressing the **OK** key from the Home screen and select **Contacts**.
- pressing the **Right soft key** from the Home screen.

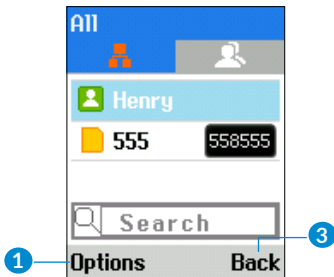

- 1 Press the **Left soft key** to access more options.
- 2 Press the **Navigation key** to select and then press **OK** key to enter the menu.
- 3 Press the **End key** to return to the previous menu.

4.2 Adding a contact

In your contacts list screen, select **Options** > **New** to add new contacts with detailed information.

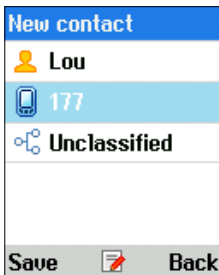

When finished, press the **Left soft key** to save.

4.3 Editing your contacts

Select a contact, press the **OK key** to access **Details**, select **Options** > **Edit**, and press the **OK key** to edit.

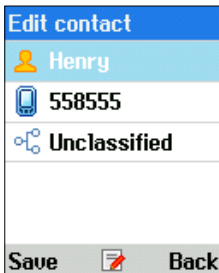

4.4 Deleting a contact

In your contacts list screen, press the **Left soft key** to access **Options**, select **Delete**, and press the **OK key** to delete.

4.5 Available options

From the contact list, you can access the following options:

New

Create a new contact on your Phone or SIM.

Write message

Send an SMS to a contact you've selected from **Contacts**.

Call

Make a call to the selected contact.

Add to blacklist

Add the selected contact to blacklist.

Delete

Delete the contact you've selected.

Delete multiple

Delete one or more contacts at a time.

Delete all

Delete all contacts at a time.

Delete phone contacts

Delete contacts stored in phone.

Delete SIM contacts

Delete contacts stored in SIM card.

Copy/Move

Copy/Move contacts from phone or SIM card to your desired location.

Import/ Export

- Import contacts

Import contacts to your phone.

- Export contacts

Export contacts from your phone or SIM card.

Others

- Speed dial

Set one or more speed dial contacts at a time.

- Own number

Set Name and Mobile of your own.

- Service number
- Memory status

Review the memory status of your phone and SIM card.

5 Calendar.....

Use Calendar to keep track of important meetings, appointments, etc.

To create new event, select the date by pressing navigation key and then press **OK key**, fill in all required information for this new event, press the Left soft key to save.

6 Gallery.....

Gallery acts as a media player for you to view photos and play videos. In addition, a set of further operations to pictures and videos are available for selection.

To access this function, press the **OK key** from the Home screen and select **Gallery**.

7 Camera



Your mobile phone is equipped with a camera for taking photos and shooting videos.

7.1 Camera

To access this function, press the **Centre soft key** from the Home screen and select **Camera**.

To take a picture

The screen acts as the viewfinder. Position the object or landscape in the viewfinder, and press the **Centre soft key** to take pictures, press **Left soft key** to save.

7.2 Video

To shoot a video

- Press the **Left soft key** and choose **Video mode** to switch to Video mode from Camera mode.
- Press the **Centre soft key** to shoot a video.
- When finished, press the **Left soft key**, it will be automatically saved. You can view the file by pressing **Gallery** in the app list.

8 Tools.....



8.1 Alarm

Your phone has a built-in alarm clock with snooze feature. You can set up to three alarms with different wake-up times.

8.2 Clock

The first clock displays the time based on your location when you insert your SIM card. You can choose other cities to show the time in their time zones.

8.3 Torch

Turn on/off the torch.

8.4 Bluetooth

You can exchange data, such as video, images, and audio, with other Bluetooth supported devices within a limited range after pairing.

8.5 Calculator

Press the up, down, left, right and Centre soft key to select "+, -, ×, ÷" and "=" respectively.

8.6 Recorder

Use this function to record audio files. The phone supports AMR. When completed, the file will be stored in Audio automatically.

8.7 My files

My files manages all the files stored on the phone, including both external microSDTM card and internal storage.

8.8 Call Filter

Take control of your calls with Call Filter, block unwanted calls and create custom blacklists.

8.9 Convert

Convert supports weight conversion and length conversion. in Audio automatically.

9 STK.....



The **STK** (SIM Toolkit) menu provides convenient SIM card management features, such as SIM card services, SIM applications.

10 Settings.....

To access this function, press the **OK** key from the Home screen and select **Settings**.

10.1 Call settings

Call Settings is a key menu for customizing call management. It lets you enable/disable call waiting, block unwanted numbers and adjust caller ID (show/hide), etc.

10.2 Phone settings

- **Date & time**

It allows you to modify date and time settings, including 12/24h format and date format (Year-Mon-Day/Mon-Day-Year/Day-Mon-Year). You can also choose to update the time display automatically by selecting **Phone settings > Auto update time**.

- **Language settings**

You can customize various language-related options, such as display language and writing language. Please note that the availability of certain languages and features may vary depending on your device model and software version.

- **Shortcut Settings**

The **Shortcut Settings** menu allows you to customize the shortcuts for quick access to various features and functions on your device. such as contacts, messages, camera, etc.

- **Auto power on/off**

You can set the power on/off times using this function.

- **Restore factory settings**

This feature allows you to reset your device to its original factory state. Before initiating the restoration process, it is important to note that all data and personalized settings will be permanently deleted. It is highly recommended to back up any important files, contacts, or data before proceeding.

10.3 Display

You can set animation effect, wallpaper, auto lock, etc. within this menu. These features and settings contribute to enhancing your display experience, allowing you to personalize and optimize your device to meet your preferences and needs.

10.4 Security

You can protect your phone by activating and changing the PIN and password, this feature also allows you to lock your phone by activating the PIN2 for Fixed dial number.

- **PIN**

The SIM card protection code is requested each time the phone is powered on.

- **Modify PIN2**

A protection code for certain SIM card features (FDN) will be requested if you attempt to access the card when the code is activated. Select to update it with a new one (between 4 and 8 digits).

- **Phone locked**

An unlock code is requested each time the phone is powered on.

- **Modify privacy password**

Change the phone's password .

* You will need to set a password before accessing this function.

- **Privacy**

This allows applications to be locked. Enter the password, and mark the checkbox to activate the lock for Call logs, Message, Contacts, My files, Calendar, etc.

- **Lock screen by end-key**

Once this feature is enabled, pressing the end key will instantly lock the screen. This feature allows you to quickly secure your device with just a press of the end key.

10.5 Profiles

The **Profiles** provides a series of settings to adapt to various scenarios, you can set the sound mode to **Normal**, **Silent**, **Meeting**, **Indoor**, **Outdoor** or **Flight mode**.

10.6 Connections

Within this menu, you can set **Data account**, **Data connection**, **Data roaming**, etc.

10.7 Voice report

Select to turn on/off voice report.

10.8 Battery Saver

Battery Saver on your phone helps conserve battery by reducing background processes and adjusting settings for optimal energy efficiency, allowing your device to last longer between charges. Activate this feature when your battery is low to extend usage time.

10.9 Regulatory & Safety

View information about your phone, such as Product Model, Manufacturer Name, IMEI, CU Reference, etc.

10.10 About

You can view Privacy and User Terms under this menu.

11 Troubleshooting.....

Before contacting the service centre, you are advised to follow the instructions below:

- You are advised to fully charge the battery for optimal operation.
- Avoid storing large amounts of data in your phone as this may affect its performance.

and carry out the following checks:

My phone can't be switched on or is frozen

- Check the battery contacts, remove and reinstall your battery, then turn your phone on.
- Check the battery power level, charge for at least 20 minutes.

My phone has not responded for several minutes

- Restart your phone by pressing and holding the **End key**.
- Remove the battery and re-insert it, then restart the phone.

My phone turns off by itself

- Check whether your phone is locked when not in use, and make sure you don't accidentally turn off your phone when locking it by pressing the **End key**.
- Check the battery charge level.

My phone can't charge properly

- Make sure you are using a standard battery and the charger from the box.
- Make sure your battery is inserted properly. It must be inserted before plugging in the charger.
- Make sure that your battery is not completely discharged; if battery power is empty for a long time, it may take around 20 minutes to display the battery charger indicator on the screen.
- Make sure charging is carried out under normal conditions (0°C to +40°C).
- When abroad, check that the voltage input is compatible.

My phone can't connect to a network or "No service" is displayed

- Try connecting in another location.
- Verify the network coverage with your operator.
- Check with your operator that your SIM card is valid.
- Try selecting the available network(s) manually.
- Try connecting at a later time if the network is overloaded.

My phone can't connect to the Internet

- Make sure that the internet access service of your SIM card is available.
- Check your phone's Internet connection settings.
- Make sure you are in a place with network coverage.
- Try connecting at a later time or another location.

Invalid SIM card

- Make sure the SIM card has been correctly inserted.
- Make sure the chip on your SIM card is not damaged or scratched.
- Make sure the service of your SIM card is available.

Unable to make outgoing calls

- Make sure you have dialled a valid number and have pressed the **call key**.
- For international calls, check the country and area codes.
- Make sure your phone is connected to a network, and the network is not overloaded or unavailable.
- Check your subscription status with your operator (credit, SIM card valid, etc.).
- Make sure you have not barred outgoing calls.
- Make sure that your phone is not in flight mode.

Unable to receive incoming calls

- Make sure your phone is switched on and connected to a network (check if the network is overloaded or unavailable).
- Check your subscription status with your operator (credit, SIM card valid, etc.).
- Make sure you have not forwarded incoming calls.
- Make sure that you have not barred certain calls.
- Make sure that your phone is not in flight mode.

The caller's name/number does not appear when a call is received

- Check that you have subscribed to this service with your operator.
- Your caller has concealed his/her name or number.

I can't find my contacts

- Make sure your SIM card is not broken.
- Make sure your SIM card is inserted properly.
- Import all contacts stored in SIM card to phone.

The sound quality of the calls is poor

- You can adjust the volume during a call by pressing the **Volume Up/down** key.
- Check the network strength .
- Make sure that the receiver, connector or speaker on your phone is clean.

I am unable to use the features described in the manual

- Check with your operator to make sure that your subscription includes this service.
- Make sure this feature does not require an **Alcatel** accessory.

When I select a number from my contacts, the number can't be dialled

- Make sure that you have correctly recorded the number in your file.
- Make sure that you have selected the country prefix when calling a foreign country.

I am unable to add a contact to my contacts

- Make sure that your SIM card contacts are not full; delete some files or save the files in the phone contacts.

My callers are unable to leave messages on my voicemail

- Contact your network operator to check service availability.

I can't access my voicemail

- Make sure your operator's voicemail number is correctly entered.
- Try later if the network is busy.

SIM card PIN locked

- Contact your network operator to obtain the PUK code (Personal Unblocking Key).

The phone can't be detected by others via Bluetooth

- Make sure that Bluetooth is turned on and your phone is visible to other users.
- Make sure that the two phones are within Bluetooth's detection range.

How can I transfer data between my phone and PC?

- If you want to transfer data between a memory card/SD card and your PC, connect your phone to the PC via the user data cable and select "SD card" on your phone. You will then be able to transfer data between the two locations.

12 Specifications.....

OS	RTOS-ThreadX
Memory	4MB ROM + 4MB RAM
Dimensions (LxWxT)	114*47.28*12.7 mm
Weight	80 g
Display	1.8" QQVGA (128x160)
Network	<ul style="list-style-type: none">• 2G-GSM:850/900/1800/1900
Connectivity	<ul style="list-style-type: none">• Bluetooth 2.1 A2DP• Type C
Audio supported formats	AMR, WAV, MP3 (customized base on region requirement)
Video supported formats	AVI, 3GP
Battery	Capacity: 1030 mAh
Expansion Slot	SIM/Dual SIMs + SD card

Note: Specifications are subject to change without prior notice.

13 Accessories.....

Standard accessories

- Battery
- Charger⁽¹⁾
- Quick Start Guide
- LCD sticker



Only use the standard batteries, chargers⁽¹⁾, and accessories along with your device.

14 Licences.....



The Bluetooth word mark and logos are owned by the Bluetooth SIG, Inc. and any use of such marks by TCL Communication Ltd. and its affiliates is under licence. Other trademarks and trade names are those of their respective owners.

**TCL T319E Bluetooth Declaration ID
Q349134**

⁽¹⁾ If sold with the device, depending on the device you purchased